

INSTALLATION MAP

To sheet: _____

Panel Group: Azimuth: Tilt: Sheet ____ / ____	Client:			Installer:			N S E W
	1	2	3	4	5	6	7
A							
B							
C							
D							
E							
F							
G							
H							
I							
J							

IQ Gateway serial label number:

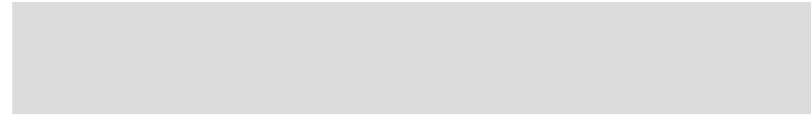

INSTALLATION MAP

To sheet: _____

Compliance with EU Directives

This product complies with the following EU Directives and can be used in the European Union without any restrictions.

- Electro Magnetic Compatibility (EMC) directive 2014/30/EU
- Low voltage directive (LVD) 2014/35/EU
- Restriction of Hazardous Substances (RoHS) 2011/65/EU

The full text of the EU declaration of conformity (DoC) is available at the following internet address <https://enphase.com/en-gb/installers/resources/documentation>

Manufacturer:

Enphase Energy Inc., 47281 Bayside Pkwy, FREMONT, CA, 94538, UNITED STATES OF AMERICA, PH: +1 707-763-4784

Importer:

Enphase Energy NL B.V., Het Zuiderkruis 65, 5215MV, 's-HERTOGENBOSCH, THE NETHERLANDS, PH: +31 73 3035859

© 2023 Enphase Energy. All rights reserved. Enphase, the e and CC logos, IQ, and certain other marks listed at <https://enphase.com/trademark-usage-guidelines> are trademarks of Enphase Energy, Inc. in the US and other countries. Data subject to change. Rev06/02-27-2023

Enphase Customer Support: <https://enphase.com/contact/support>

QUICK INSTALL GUIDE



Install the Enphase IQ7A Microinverter

To install Enphase IQ7A Microinverters, read and follow all warnings and instructions in this guide and in the *Enphase IQ7A Microinverter Installation and Operation Manual* at enphase.com/support. Safety warnings are listed on the back page of this guide.

The microinverter has a Class II double-insulated rating, which includes ground fault protection (GFP). To support GFP, use only PV modules equipped with DC cables labeled PV wire or PV cable. Refer to local electrical codes and standards for grounding requirements of PV array and racking.

IMPORTANT: Enphase IQ Microinverters require the IQ Cable and are not compatible with previous Enphase cabling. An IQ Gateway is required to monitor performance of the IQ Microinverters. The IQ Accessories work only with Enphase IQ Microinverters.

Note: Installer must check the manufacturing date of the products to ensure that the installation date is within one year of the manufactured date of the products. Contact your local distributor to validate the date code.

PREPARATION

A) Download the Enphase Installer App and open it to log in to your Enphase Installer Platform account. With this app, you can scan microinverter serial numbers and connect to the Enphase IQ Gateway to track system installation progress. To download, go to <https://enphase.com/en-gb/installers/apps> or scan the QR code at right.



B) Refer to the following table and check PV module compatibility at: UK: <https://enphase.com/en-gb/installers/microinverters/calculator> ANZ: <https://enphase.com/en-gb/installers/microinverters/calculator>

Model	DC Connector Adapter Cable	PV module cell count
IQ7A-72-2-INT	Stäubli MC4	Pair with 60 cell/120-half-cell or 72 cell/144-half-cell

C) In addition to the Enphase Microinverters, PV modules and racking, you will need these Enphase items:

- An Enphase IQ Gateway (model ENV-S-EM-230 or ENV-S-WM-230 or ENV-S-WB-230) communications gateway is required to monitor solar production and may be required to propagate a grid profile to the microinverters.
- NOTE:** Depending on your region, IQ Series Microinverters may not produce until an IQ Gateway is installed and configured with the appropriate grid profile. See the [IQ Gateway Quick Install Guide](#) for details.
- Enphase IQ Relay, single-phase (Q-RELAY-1P-INT) or Enphase IQ Relay, multi-phase (Q-RELAY-3P-INT). For Italy region, use IQ Relay (Q-RELAY-2-3P-ITA) for both single-phase and multi-phase application
- Tie wraps or cable clips (ET-CLIP-100 - works with both multi-phase and single-phase cable)
- The multi-phase IQ Relay also provides phase coupling to allow microinverters on all phases to communicate with the IQ Gateway. Use a Phase Coupler (LPC-01) for multi-phase system for phase coupling if IQ Relay is not installed in the multi-phase system.
- Enphase Sealing Caps (Q-SEAL-10): for any unused connectors on the Enphase IQ Cable
- Enphase Terminator (Q-TERM-R-10 for single-phase or Q-TERM-3P-10 for multi-phase): one for each AC cable segment end.
- Enphase Disconnect Tool (Q-DISC-10)
- Enphase IQ Cable for single-phase or multi-phase:

Cable model	Connector spacing*	PV module orientation	Connectors per box
Single-phase			
Q-25-10-240	1.3 m	Portrait (all)	240
Q-25-17-240	2.0 m	Landscape (60- and 96-cell)	240
Q-25-20-200	2.3 m	Landscape (72-cell)	200

Multi-phase			
Q-25-10-3P-200	1.3 m	Portrait (all)	200
Q-25-17-3P-160	2.0 m	Landscape (60- and 96-cell)	160
Q-25-20-3P-160	2.3 m	Landscape (72-cell)	160

*Allows for 30 cm of cable slack.

- D) Check that you have these other items:
- An AC junction box or AC isolator.
 - Tools: screwdrivers, wire cutter, voltmeter, torque wrench, sockets, and wrenches for mounting hardware
 - Field Wireable Connectors (Q-CONN-R-10M and Q-CONN-R-10F for single-phase IQ Cable or Q-CONN-3P-10M and Q-CONN-3P-10F for multi-phase IQ Cable): optional male and female connectors for single-phase connections.

E) Protect your system with lightning and/or surge suppression devices. It is also important to have insurance that protects against lightning and electrical surges.

Note for installations in South Africa only: For the Enphase warranty to be valid in South Africa, Enphase requires that you protect your system with a lightning and/or Surge Protection Device (SPD) as a part of the installation. We recommend that the SPD meets the following electrical requirements.

Electrical Characteristics		Value
Clamping Voltage of L-N, L-G, N-G @5kA(8/20 μs)	Up-5kA	600 V

F) Plan your AC branch circuits to meet the following limits for maximum number of microinverters per branch when protected with a 20 A over-current protection device (OCPD). For multi-phase installations, use a 3-pole 25 A OCPD.

Maximum* IQ7A Microinverters per AC branch circuit	
Single-phase	10 (20 A OCPD)
Multi-phase	30 (20 A OCPD) 39 (25 A OCPD only in ANZ)

* Limits may vary. Refer to local requirements to define the number of microinverters per branch in your area.

G) Size the AC wire gauge to account for voltage rise. Select the correct wire size based on the distance from the beginning of the Enphase IQ Cable to the breaker in the load center.

Best practice: Center-feed the branch within the circuit to minimize voltage rise in a fully-populated branch.

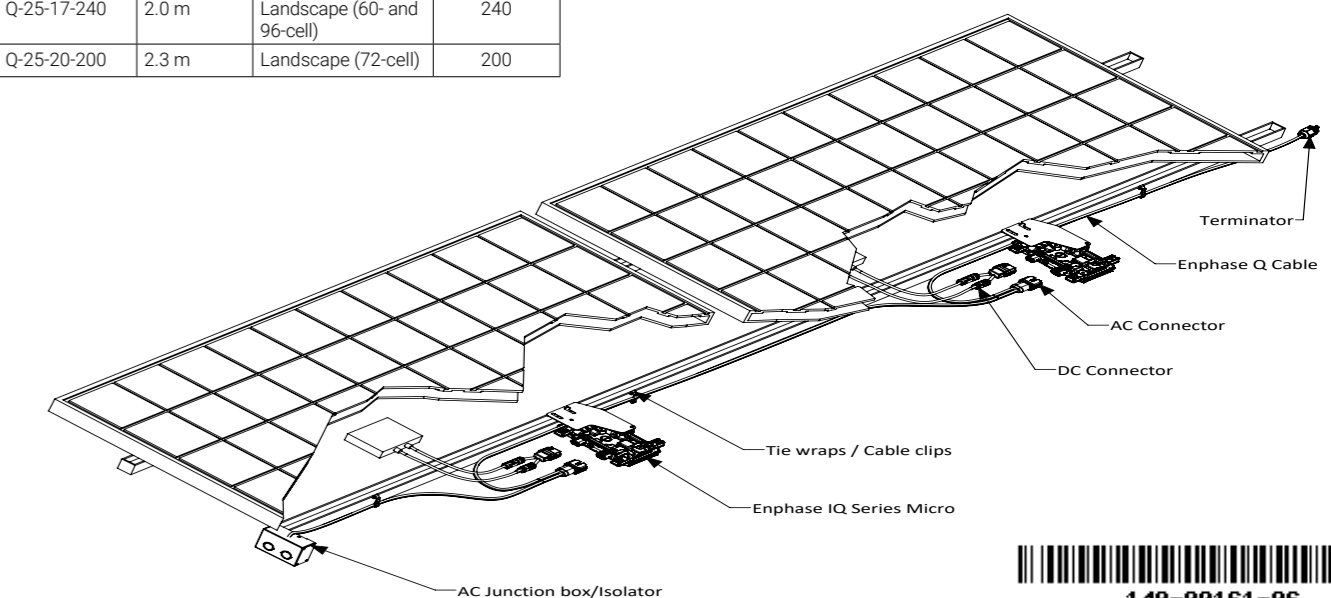

INSTALLATION

1 Position the Enphase IQ Cable

- Plan each cable segment to allow connectors on the Enphase IQ Cable to align with each PV module. Allow extra length for slack, cable turns, and any obstructions.
- Mark the approximate centers of each PV module on the PV racking.
- Lay out the cabling along the installed racking for the AC branch circuit.
- Cut each segment of cable to meet your planned needs.

WARNING: When transitioning between rows, secure the cable to the rail to prevent cable or connector damage. Do not count on the connector to withstand tension.

2 Position the junction box/AC isolator

- Verify that AC voltage at the site is within range:

Single-phase service		Three-phase service	
L1 to N	207 to 253 VAC	L1 to L2 to L3	360 to 440 VAC
		L1, L2, L3 to N	207 to 253 VAC

- Install a junction box/AC isolator at a suitable location on the racking.
- Provide an AC connection from the junction box/AC isolator back to the electricity network connection using equipment and practices as required by local jurisdictions.

3 Mount the microinverters

- The microinverters can be mounted beneath the modules either horizontal or vertical orientation to the module and must be mandatorily protected from direct exposure to rain, UV, and other harmful weather events. Refer to the "Vertical mount" image for clearance requirements during vertical mounting.
- Mount the microinverter horizontally bracket side up or vertical. Always place it under the PV module, protected from direct exposure to rain, sun, and other harmful weather events. Allow a minimum of 1.9 cm (3/4") between the roof and the microinverter. Also allow 1.3 cm (1/2") between the back of the PV module and the top of the microinverter. For vertical mount also maintain >300 mm (12") clearance from the edges of the PV module to protect the microinverter from direct exposure to rain, UV, and other harmful weather events.

WARNING: Install the microinverter under the PV module to avoid direct exposure to rain, UV, and other harmful weather events. Do not mount the microinverter upside down.

- Torque the mounting fasteners as follows. Do not over torque.

- 6 mm mounting hardware: 5 N m
- 8 mm mounting hardware: 9 N m
- When using mounting hardware, use the manufacturer's recommended torque value

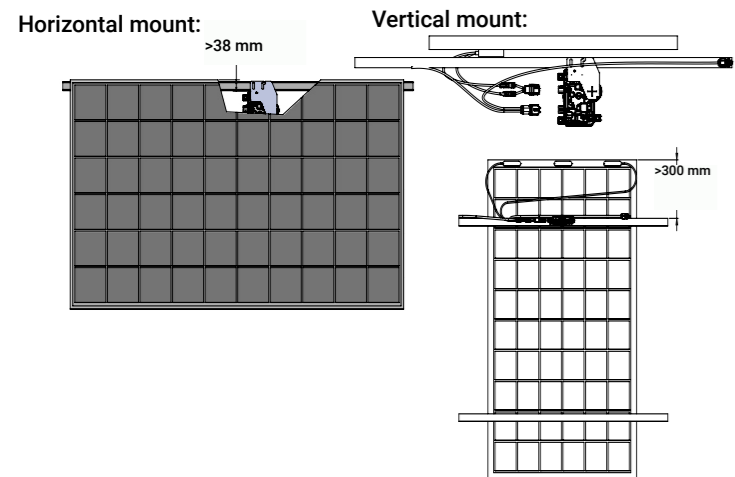

4 Create an installation map

Create a paper installation map to record microinverter serial numbers and position in the array.

- Peel the removable serial number label from each microinverter and affix it to the respective location on the paper installation map.
- Peel the label from the IQ Gateway and affix it to the installation map.
- Always keep a copy of the installation map for your records.

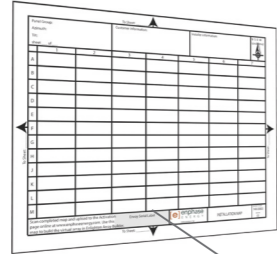

Affix serial number labels

5 Manage the cabling

- Use cable clips or tie wraps to attach the cable to the racking. The cable must be supported at least every 300 mm.
- Dress any excess cabling in loops so that it does not contact the roof. Do not form loops smaller than 12 cm in diameter.

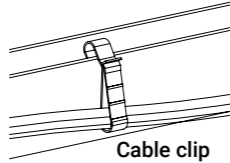

Cable clip

6 Connect the microinverters

- Connect the microinverter. Listen for a click as the connectors engage.
- Cover any unused connectors on the AC cable with Enphase Sealing Caps. Listen for a click as the sealing caps engage.

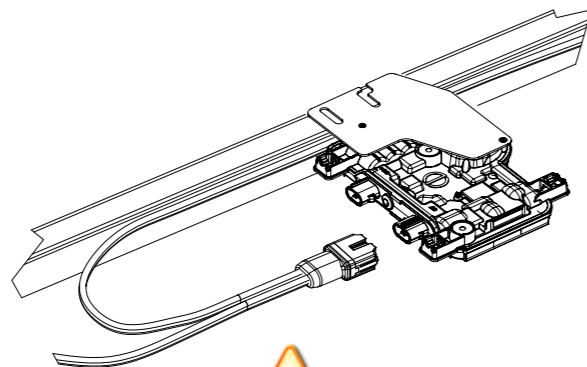

WARNING: Install sealing caps on all unused AC connectors as these connectors become live when the system is energised. Sealing caps are required for protection against moisture ingress.

To remove a sealing cap or AC connector, you must use an Enphase Disconnect Tool.



Enphase Disconnect Tool

7 Terminate the unused end of the cable

Single-phase IQ Cable	Three-phase IQ Cable
A) Remove 13 mm of the cable sheath from the conductors. Use the terminator body loop to measure.	A) Remove 20 mm of the cable sheath from the conductors.
B) Slide the hex nut onto the cable. The grommet inside the terminator body must remain in place.	B) Slide the hex nut onto the cable. The grommet inside the terminator body must remain in place.
C) Insert the cable into the terminator body so that the two wires land on opposite sides of the internal separator.	C) Insert the cable into the terminator body so that the four wires land on separate sides of the internal separator.
D) Insert a screwdriver into the slot on the top of the terminator to hold it in place. Hold the terminator body stationary with the screwdriver and turn only the hex nut to prevent the conductors from twisting out of the separator. Torque the nut to 7.0 N m.	D) Bend the wires down into the recesses of the terminator body and trim as needed. Place the cap over the terminator body. Insert a screwdriver into the slot on the terminator cap to hold it in place. Rotate the hex nut with your hand or a wrench until the latching mechanism meets the base. Do not over torque.
E) Attach the terminated cable end to the PV racking with a cable clip or tie wrap so that the cable and terminator do not touch the roof.	E) Attach the terminated cable end to the PV racking with a cable clip or tie wrap so that the cable and terminator do not touch the roof.

WARNING: The terminator cannot be re-used. If you unscrew the nut, you must discard the terminator.

8 Complete Installation of the junction box/AC isolator

- Connect the Enphase IQ Cable into the junction box/AC isolator.
- Note that the IQ Cable uses the following wiring colour code:

Single-phase	Multi-phase
Brown – L1 active	Brown – L1 active
Blue - Neutral	Black – L2 active
	Grey – L3 active
	Blue - Neutral

NOTE: The IQ Cable internally rotates L1, L2, and L3 to provide balanced 400 VAC (three-phase), thus alternating phases between microinverters.

NOTE: Minimise the number of unused IQ Cable connectors with three-phase systems. When cable connectors are left unused on a three-phase system, it creates a phase imbalance on the branch circuit. If multiple cable connectors are skipped over multiple branch circuits, the imbalance can multiply.

WARNING: To prevent irreversible damage to the system confirm colour codes at connections before energising the AC Supply. Failure to comply voids the warranty.

9 Connect the PV modules

DANGER! Electric shock hazard. The DC conductors of this PV system are ungrounded and may be energised.

- Connect the DC leads of each PV module to the DC input connectors of the microinverter.
- Check the LED on the connector side of the microinverter. The LED flashes six times when DC power is applied.
- Mount the PV modules above the microinverters.

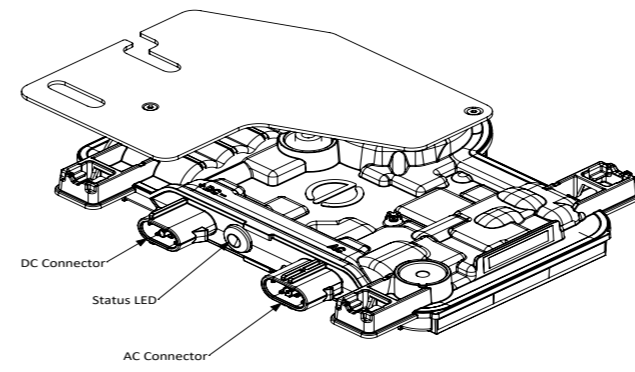

10 Energise the system

- Turn ON the AC disconnect or circuit breaker for the branch circuit.
- Turn ON the main utility-grid AC circuit breaker. Your system will ramp up to full producing power **after a six-minute wait time**.
- Check the LED on the connector side of the microinverter:

LED	Indicates
Flashing green	Normal operation. AC grid function is normal and there is communication with the IQ Gateway.
Flashing orange	The AC grid is normal but there is no communication with the IQ Gateway.
Flashing red	The AC grid is either not present or not within specification.
Solid red	There is an active "DC Resistance Low, Power Off" condition. To reset, refer to the <i>Enphase IQ Gateway Installation and Operation Manual</i> at: https://enphase.com/en-gb/installers/resources/documentation

ACTIVATE MONITORING AND SELECT GRID PROFILE

After you have installed the microinverters, follow the procedures in the *Enphase IQ Gateway Quick Install Guide* to activate system monitoring, set up grid management functions, and complete the installation.

- Connect the IQ Gateway
- Detect devices and select grid profile
- Connect to Enphase Installer App
- Register the system
- Build the virtual array

SAFETY

IMPORTANT SAFETY INSTRUCTIONS
SAVE THIS INFORMATION. This guide contains important instructions to follow during installation of the Enphase IQ7A Microinverters.

⚠	WARNING: Hot surface.
⚠	WARNING: Refer to safety instructions.
⚠	DANGER: Risk of electric shock.
ℹ	Refer to manual
⚡	Double-Insulated

Safety Symbols

⚠	DANGER: Indicates a hazardous situation, which if not avoided, will result in death or serious injury.
⚠	WARNING: Indicates a situation where failure to follow instructions may be a safety hazard or cause equipment malfunction. Use extreme caution and follow instructions carefully.
⚠	WARNING: Indicates a situation where failure to follow instructions may result in burn injury.
✓	NOTE: Indicates information particularly important for optimal system operation.

General Safety

⚠	DANGER: Risk of electric shock. Do not use Enphase equipment in a manner not specified by the manufacturer. Doing so may cause death or injury to persons, or damage to equipment.
⚠	DANGER: Risk of electric shock. Be aware that installation of this equipment includes risk of electric shock.
⚠	DANGER: Risk of electric shock. The DC conductors of this photovoltaic system are ungrounded and may be energised.
⚠	DANGER: Risk of electric shock. Always de-energise the AC branch circuit before servicing. Never disconnect the DC connectors under load.
⚠	DANGER: Risk of electric shock. Risk of fire. Only use electrical system components approved for wet locations.
⚠	DANGER: Risk of electric shock. Risk of fire. Only qualified personnel should troubleshoot, install, or replace Enphase Microinverters or the Enphase IQ Cable and Accessories.
⚠	DANGER: Risk of electric shock. Risk of fire. Ensure that all AC and DC wiring is correct and that none of the AC or DC wires are pinched or damaged. Ensure that all AC junction boxes are properly closed.
⚠	DANGER: Risk of electric shock. Risk of fire. Do not exceed the maximum number of microinverters in an AC branch circuit as listed in this guide. You must protect each microinverter AC branch circuit with a 20A (single-phase) or 25A (three-phase) maximum breaker or fuse, as appropriate.
⚠	DANGER: Risk of electric shock. Risk of fire. Only qualified personnel may connect the Enphase Microinverter to the utility grid.
⚠	WARNING: Risk of equipment damage. Enphase male and female connectors must only be mated with the matching male/female connector.
⚠	WARNING: Before installing or using the Enphase Microinverter, read all instructions and cautionary markings in the technical description, on the Enphase Microinverter System, and on the photovoltaic (PV) equipment.
⚠	WARNING: Do not connect Enphase Microinverters to the grid or energise the AC circuit(s) until you have completed all of the installation procedures and have received prior approval from the electrical utility company.
⚠	WARNING: When the PV array is exposed to light, DC voltage is supplied to the PCE.
⚠	WARNING: Incorrect phase wiring can cause irreversible damage to the microinverter installation. Check all wiring before energising.
✓	NOTE: To ensure optimal reliability and to meet warranty requirements, install the Enphase Microinverters and Enphase IQ Cable according to the instructions in this guide.
✓	NOTE: Provide support for the Enphase IQ Cable at least every 300 mm.

General Safety, continued

✓	NOTE: Perform all electrical installations in accordance with all applicable local electrical codes.
✓	NOTE: The AC and DC connectors on the cabling are rated as a disconnect only when used with an Enphase Microinverter.
✓	NOTE: Protection against lightning and resulting voltage surge must be in accordance with local standards.

Microinverter Safety

⚠	DANGER: Risk of electric shock. Risk of fire. Do not attempt to repair the Enphase Microinverter; it contains no user-serviceable parts. If it fails, contact Enphase customer service to obtain an RMA (return merchandise authorisation) number and start the replacement process. Tampering with or opening the Enphase Microinverter will void the warranty.
⚠	DANGER: Risk of fire. The DC conductors of the PV module must be labeled "PV Wire" or "PV Cable" when paired with the Enphase Microinverter.
⚠	WARNING: You must match the DC operating voltage range of the PV module with the allowable input voltage range of the Enphase Microinverter.
⚠	WARNING: The maximum open circuit voltage of the PV module must not exceed the specified maximum input DC voltage of the Enphase Microinverter.
⚠	WARNING: Risk of equipment damage. Install the microinverter under the PV module to avoid direct exposure to rain, UV, and other harmful weather events. Always install the microinverter upside down. Do not expose the AC or DC connectors (on the Enphase IQ Cable connection, PV module, or the microinverter) to rain or condensation before mating the connectors.
⚠	WARNING: Risk of equipment damage. The Enphase Microinverter is not protected from damage due to moisture trapped in cabling systems. Never mate microinverters to cables that have been left disconnected and exposed to wet conditions. This voids the Enphase warranty.
⚠	WARNING: Risk of equipment damage. The Enphase Microinverter functions only with a standard, compatible PV module with appropriate fill-factor, voltage, and current ratings. Unsupported devices include smart PV modules, fuel cells, wind or water turbines, DC generators, and non-Enphase batteries, etc. These devices do not behave like standard PV modules, so operation and compliance is not guaranteed. These devices may also damage the Enphase Microinverter by exceeding its electrical rating, making the system potentially unsafe.
⚠	WARNING: Risk of skin burn. The chassis of the Enphase Microinverter is the heat sink. Under normal operating conditions, the temperature could be 20°C above ambient, but under extreme conditions the microinverter can reach a temperature of 90°C. To reduce risk of burns, use caution when working with microinverters.
✓	NOTE: The Enphase Microinverter has field-adjustable voltage and frequency trip points that may need to be set, depending upon local requirements. Only an authorised installer with the permission and following requirements of the local electrical authorities should make adjustments.

Enphase IQ Cable Safety

⚠	DANGER: Risk of electric shock. Do not install the Enphase IQ Cable terminator while power is connected.
⚠	DANGER: Risk of electric shock. Risk of fire. When stripping the sheath from the Enphase IQ Cable, make sure the conductors are not damaged. If the exposed wires are damaged, the system may not function properly.
⚠	DANGER: Risk of electric shock. Risk of fire. Do not leave AC connectors on the Enphase IQ Cable uncovered for an extended period. You must cover any unused connector with a sealing cap.
⚠	DANGER: Risk of electric shock. Risk of fire. Make sure protective sealing caps have been installed on all unused AC connectors. Unused AC connectors are live when the system is energised.
⚠	WARNING: Use the terminator only once. If you open the terminator following installation, the latching mechanism is destroyed. Do not reuse the terminator. If the latching mechanism is defective, do not use the terminator. Do not circumvent or manipulate the latching mechanism.
⚠	WARNING: When installing the Enphase IQ Cable, secure any loose cable to minimise tripping hazard.
✓	NOTE: The Enphase Microinverter models listed in this guide do not require grounding electrode conductors (GEC), equipment grounding conductors (EGC), or grounded conductor (neutral). The microinverter has a Class II double-insulated rating, which includes ground fault protection (GFP). To support GFP, use only PV modules equipped with DC cables labeled PV Wire or PV Cable.
✓	NOTE: When looping the Enphase IQ Cable, do not form loops smaller than 12 cm in diameter.
✓	NOTE: If you need to remove a sealing cap, you must use the Enphase disconnect tool.
✓	NOTE: When installing the Enphase IQ Cable and accessories, adhere to the following: <ul style="list-style-type: none"> Do not expose the terminator or cable connections to directed, pressurised liquid (water jets, etc). Do not expose the terminator or cable connections to continuous immersion. Do not expose the terminator or cable connections to continuous tension (e.g., tension due to pulling or bending the cable near the connection). Use only the connectors and cables provided. Do not allow contamination or debris in the connectors. Use the terminator and cable connections only when all parts are present and intact. Do not install or use in potentially explosive environments. Do not allow the terminator to come into contact with open flame. Fit the terminator using only the prescribed tools and in the prescribed manner. Use the terminator to seal the conductor end of the Enphase IQ Cable; no other method is allowed.

Note for installations in South Africa only: For IQ7 series product used in South Africa, Check the Enphase website (<https://www.enphase.com/southafrica>) for the latest user documentations.

Note for third party products:

Any third-party manufacturer or importer product(s) used to install or commission Enphase product(s) shall comply with the applicable EU Directive(s) and requirements in the EEA (European Economic Area). It is the responsibility of the installer to confirm that all such products are labelled correctly and have the required compliant supporting documentation.